1 Product Introduction

The JCM Series solenoid metering pumps offer an extensive range of features, including microprocessor control for accurate and flexible automation in response to instrument signals. The microprocessor design employs a customized liquid crystal display (LCD) and tactile response keypad. The “state-of-the-art” surface mount electronics are fully encapsulated to ensure protection in its working environment. All external inputs and outputs are opto-isolated from the microprocessor.

2 Caution

When operating the metering pump, please pay attention to the follows:



Always wear the protective clothing (protective gloves and safety glasses) when working on the pump. Addition, get the relative preventive action from your chemical supplier.



Select the material of the pump head according to the dosing solution. If you have questions, please see the Electromagnetic Metering Pumps Selection Guide and the map of chemical properties, or get information from the local dealer and service sector.



The size for the flexible and hard pipe on both suction point and discharge point can't be narrowed. Before operation, please make sure all the pipe has been connected on the joint firmly. If the flexible pipe is used, suggesting the whole pipe is protected in order to avoid any injury which is caused by the crack of the pipe or any other accidental damage. If the pipe is exposed under the sun all the time, then black pipe which is ultraviolet radiation resistance should be installed, at the same time, please check the pipe often and replace that if necessary.



There is a transparent PVC pipe in the carton, but this pipe is just used to joint the return pipe, can't be used as the inlet and outlet pipe.



Re-spin 1/8-1/4 laps, after all the pipes have rotated to the seal ring, but not too tight. The connector, seal ring, and the pump head would be damaged and the pump can not work if the pipes were too tight or using the wrench. All the pump heads of JCM pump are sealed by seal ring, DO NOT use the adhesive tape to seal the screw thread.



A back pressure valve will be asked to avoid the siphoning occurred when there is no pressure suction, low pressure poured in or suctioned under the tank.



In order to reduce the dangerous from the splashing when disassembly or maintenance the pump, installed a three-way valve is the best way.

3. Unpacking

Some of the following parts are available in the packing, if there is any damage for the pump or the spare parts, please contact with us!



Metering Pump



Bottom Valve

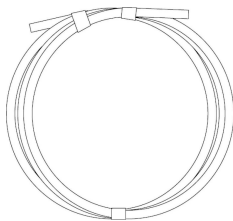

Pipe



Injection Valve



Tube weight

4. Installation

4.1 It is better to install the pump in the area where is near the tank and the power, also which is convenience for the maintenance. Meanwhile, the temperature is not higher than 50°C. If the pump is exposed under the sun all the time, the black ultraviolet radiation resistance pipe is suggested to be installed.

4.2 Installation of the pump

There are two ways for the installation:

A: Priming Installation(Ideal installation)

B: Suction-up Installation

This installation way can be used if the suction head is less than 1.5 meters and the dosing solution's proportion is NOT greater than the water's. If the solution has a large proportion, please contact the service sector.

Attention: The suction and discharge valves of the metering pump must be perpendicular to the ground, when installing, DO NOT install pump head and interfaces horizontally.

4.2.1 The ideal installation is put the pump and the tank on the same level, then the pipe is filled with the solution all the time and make the pump suction the solution freely, which can reduce the chances of failure suction. A back pressure valve will be asked to avoid the siphoning accrued when there is no pressure suction, low pressure poured or suctioned under the tank. We suggest Suction-up Installation for the high-viscosity solution.

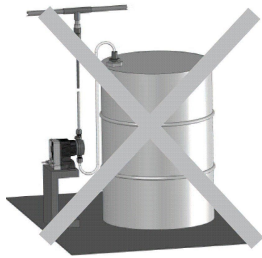

Wrong

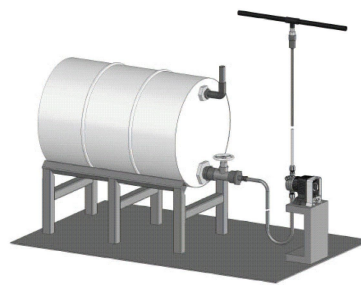

Correct

4.2.2 In consideration to the replacement of the tank, when mounting, the pump can be used our AILIPU supplied bracket, and mounted on the top of the tank directly.

4.2.3 Suction-up – Fixed in the tank

The pump can be mounted in the tank which have the fitting model.

4.2.4 Suction-up – Fixed in the shelf

The pump can be also mounted in the shelf but make sure the length of the head is less than 1.5m!

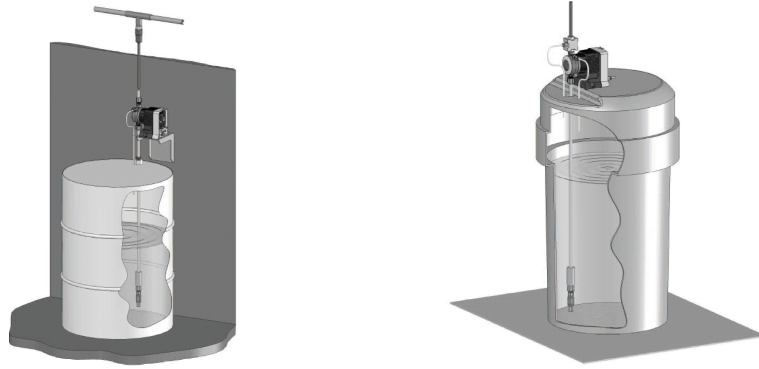

4.3 Pipe

- A. Just the white pipe is used.
- B. The transparent PVC pipe can't be used at the discharge point, or the pipe will be broken by the pressure from the pump.
- C. Before the installation, all the end faces of the pipes need to be cut trimly.
- D. When screw the screw cap and connection joint, please don't use the wrench.

4.4 Four-fuction valves(4-FV)

The accessories delivered together with the pump haven't included this valve, but according to your usage, if you think this is necessary for the operation, please make attention to buy one, the detail function of this valve is as below:

- A. Eject the air in piping through three-fuction valve to enhance the precision of metering.
- B. Releasing pressure(Automatic). If the discharge pipe is over pressure, the valve will be open, and the released liquid returns to the solution tank.
- C. Reducing pressure(manual). When pulling handle, The released liquid returns to solution tank through the discharge pipe.
- D. Sampling.

4.4.1 The Installation of the Four-Function Valve

Take off the nut which is on the top of pump head before installation, then install 4-FV. Spin the 4-FV until it contacts with the seal ring. Re-spin 1/8~1/4 circles to keep the liquid off leakage. Remember NOT too tight to avoid any distortion or break in seal rings and connections. Connect the piping to 4-FV as the returning tube of the solution tank. Do NOT put this pipe into the solution tank.

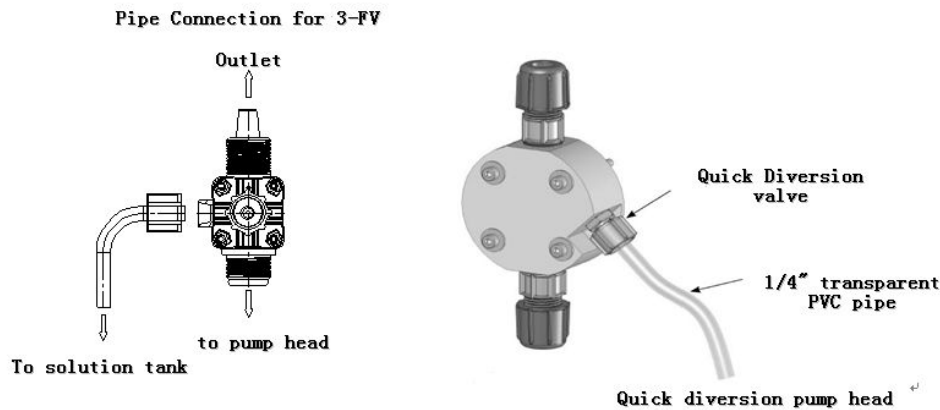

4.5 Quick diversion

When the pump head is assembled a valve who is used to draw the water quickly, then the additional 1/4" transparent PVC pipe need to be connected at the peaked nozzle. This pipe need to be together with the tank, but can't be immersed in the solution.

4.6 Installation of the Foot valve and Suction Pipe

Foot valve is used as a one-way valve. It makes the pump start easily in Suction-up Installation. It stands vertically at the bottom of solution tank and immerses in the liquid. If there is any deposit on the bottom of tank, please make sure there is 50 mm at least from the tank bottom.

Together with a tube weight can help the valve stands vertically.

4.6.1 Connect Foot valve with an end of Suction Tube.

4.6.2 Let the pipe through out the tube weight till it touched to the screw cap on the foot valve.

4.6.3 Sheath Suction tube with the Ceramic tube to increase its weight. Put the tubes and Foot valve into the solution tank. Notice that the Foot valve must be vertical, and 50 mm at least from the tank bottom. Connect the other end of Suction tube to the head of the pump.

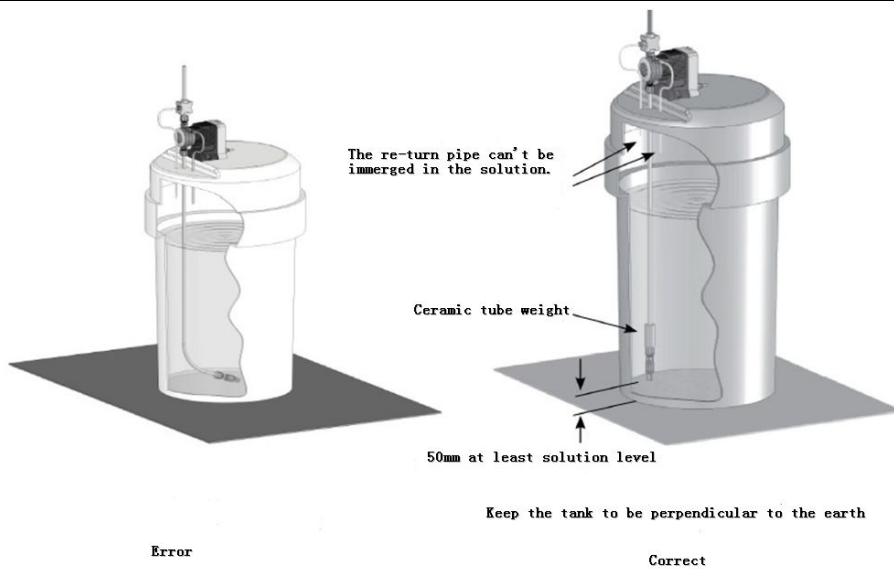

4.7 Installation of injection valve

Injection valve keeps the solution off flowing back. Connecting the suction end of injection valve to discharge pipe, and connecting the discharged end of injection valve to the dosing pipe. Seal pipes with raw rubber tapes.

The installation detail please take the reference as below:

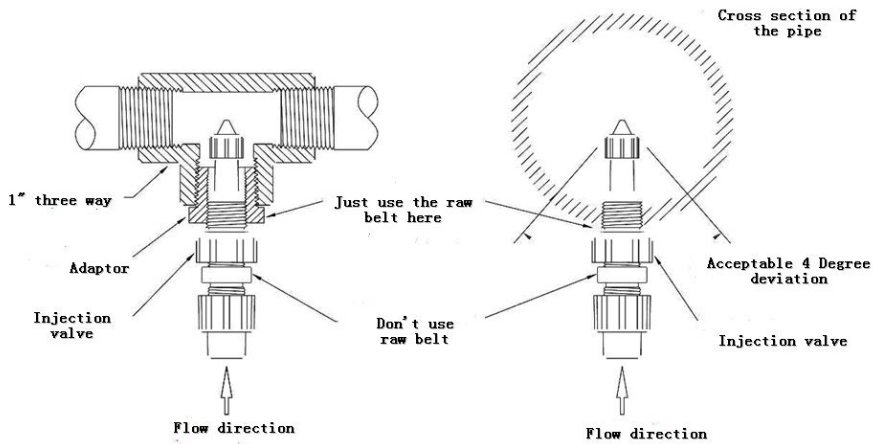

5. Operation

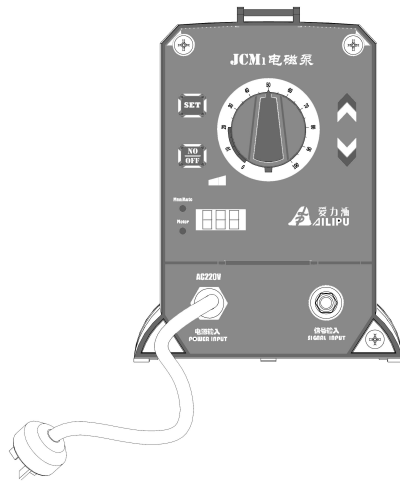

SET: When the pump stopped, this key is used to change the manual control and the remoted control.

ON/OFF: Used to control the start / stop of the pump and save & exit.

INDICATOR: Power indicator and Mode indicator

- A. Power Light:
 - a. The light will be on when there is the power come in.
 - b. The light will be off when there is no power.
- B. Control Model Light:
 - a. When manual control, the light will be off.
 - b. When remote control, the light will be on.

POWER: AC100-240V power inlet

Pump Speed Adjust Key: Used manual control of the stroke per minute, max speed will be 240/Min, min will be 0.

Signal Connection End: Used for the remoted control, available with these function:

- A. 4-20mA signal input
- B. Liquid level test
- C. Remoted on/off.
- D. Pulse Input
- E. Pulse output

Note: 4-20mA signal & Pulse signal is optional, can only choose one.

5.1 Start and Adjustment

The pump can prime automatically when the pump head is below 1.5 m.

5.1.1 Start Suction Water Quickly

Please read thoroughly of this part before the operation.

When all the caution has been paid attention, and the pump has been ready, you can open the pump as the following steps:

- A. Start the Power.

-
- B. When the pump is running, please let the stroke length at 100% position.
 - C. Spin the quickly drawing water key 1 or 2 circle counter-clock wise.
 - D. Suction pipe need to be from the tank and filled with the liquid.
 - E. When some solution drains from the pipe of the quick diversion valve, please rotate the key clock wise and off the pump power.
 - F. The pump has finished the prime.

5.1.2 Start the Four-function Valve

Please read thoroughly of this part before the operation.

When all the caution has been paid attention, and the pump has been ready, then you can open the pump as the following steps:

- A. Start the power.
- B. When the pump is running, please let the stroke length at 100% position.
- C. Spin 1/4 circle of the black key counter-clock wise, then the function pipe will be from the tank and filled with the solution. When some solution drains from the pipe of the 4-FV, please rotate the key 1/4 clock wise and off the pump power.
- D. The pump has finished the suction.



If the pump can suction up, please disassemble the 3-FV and check valve, at the same time fill the pump head full with the liquid then assemble the check valve again and do the prime section as above.

5.2 Adjustment output

5.2.1 Speed adjustment: adjust the percent of maximum strokes per minute.

5.2.2 Stroke adjust knob: adjust the percent of maximum of diaphragm stroke. The right rotation increases the output percent of each stroke.

5.3 Outlet flow adjustment:

After pump head primes liquid, the adjustment of output flow must be done. The formula as follows:

Pump output = maximum output * speed% * stroke %

5.4 Calibration

After determine the approximate flow rate, the pump should be calibrated to adjust the speed and stroke to the actual needs of the flow:

5.4.1 Manual control mode:

- A. Make sure the pump head is full of the dosing solution, and all connections are ready.
- B. Put foot valve in calibration columnne whose capacity must be over 1000 ml.
- C. Power up the pump and change to Internal control mode, eject the air in pump head and suction pipe out.
- D. Stop the pump, add liquid to the calibration columnne to initial level.

E. Make the pump to run for a period time(at least 5 stroke) and record the stroke numbers. It is better for the calibration result if the running time is longer.

F. Repeat the steps 1~7 if the output is larger or smaller.

5.4.2 The steps of calibration under External remote control mode.

A. As the pump speed is controlled by the external parts device, just the output of per stroke can be calibrated..

B. Fill the Pump head with the dosing solution. After connecting the Discharge pipe to the dosing end, put Foot valve and filter components into a scaled container of which should be 1000 ml or more.

C. Under the internal manual control mode, adjust the speed to maximum, eject the air in pump head and suction pipe out.

D. Regulating pressure control.

E. Mark the container liquid level. Re-injection the solution, so that level to reach an initial scale value.

F. Start the pump, and count the number of strokes in a minute, then stop the pump.

G. Record the pump's output in a minute, then divided by the number of strokes. Get the size of each stroke output.

For example: 500ml / 100 strokes = 5.0 ml per stroke. Use this number with the required output for comparison.

Repeat the steps 1~7 if the output is more or less.

5.5 Control Mode

5.5.1 Local mode function (Factory default state PO)

A.  Control start /stop of the pump.  Adjust the capacity percent 0-100%

B. Signal: ①Remoted on/off, connect the remote signal, then press , the remote function will be achieve.

②Level control: When the level is lower than the point the user set, the pump will be stopped automatically. At same time, the display screen will show .



③Pulse Signal: A pulse signal is output when from the pump's a round trip.

Note:  will be off when manual mode.





5.5.2 Remote Control Mode:

Press  three or more seconds until  indicator light is on, then the remote control mode is

achieved.

Note: If any accidents, such as the broken of the pump head, the diaphragm or the leakage of the pipe, please press  immediately and stop the pump. When the accident has been settled, press  again to achieve the remote signal control, which means,  is the emergency key for the remote control mode.

5.5.3 Remote 4-20mA Mode:

When the pump has finished the work, please press  until the indicator light  is off. In other words, when  is on, means the pump is still under the remote 4-20mA control mode state, at this moment,  is lost the adjustment function.

Function:

A. 4-20mA remote control. When the input signal is 4mA, the output frequency of the pump is 0%, and when 20mA, the frequency will be 100%.

Note 1:

If the signal is less than 4mA or more than 20mA, the frequency will be still 0% or 100%.

Note 2:





The 4-20mA signal is with the proportional relationship to the display on the pump screen, the detail calculation is as below:

$$\{ (\text{Input signal No.} - 4) / 16 \} * 100\% = \text{Screen display}$$

For Example: If there is 12mA signal input, $\{(12-4)/16\} * 100\% = 50\%$

If there is 8mA signal input, $\{(8-4)/16\} * 100\% = 25\%$

Note 3: When the pump finished the production, the signal has been adjusted to Zero Position, but as different meter with different output signal, the user need to adjust the signal to Zero Position again before using. The detail adjustment as below:

- a. Achieve the pump to remote control mode.
- b. Input 20mA signal, press  together with  until the screen display 20 and 100 on turn.
- c. Input 4mA signal, press  together with  until the screen display 0 and 4 on turn.
- d. At last please press  to save and exit.

You can test whether have been adjust to Zero position or not: input 10mA signal and the

screen will display 50 and 12 on turn, when means the signal adjust to Zero Position has been achieved.





- B. Remote ON/OFF: Please connect the signal cable first, then press Press , the remoted control mode will be achieved.
- C. Level control: When the level is lower than the point the user set, the pump will be stopped automatically. At same time, the display screen will show **E0**.
- D. Pulse control mode:



Pulse control mode as the optional control mode for the user's reference, but if choose pulse control mode, 4-20mA signal will be cancel, so pulse control and 4-20mA control only can be choose one for the device using.

The detail control mode as below:



- a. The pump can receive 5-24V pulse signal.
- b. Pump way into multiplication and division, when the coefficient is 1, the pump can receive 0-240/min signal, please check the set of multiplication and division coefficient as following:

At first please make sure the pump is under the remote control mode. Press  together with  until the screen displays P, when the "P" is disappear, press  will let the coefficient larger, and press  will let the coefficient smaller, then please let the coefficient is changeable between -99 --99. When the coefficient is at 0—99, which is at the multiplication way. When the coefficient is at -99 – 0, which is at the division way.

Please press  save and exit when the user has get the detail coefficient which he need.

- E. Pulse signal feedback: The pump will output a pulse signal according it's every round trip.

Note: If the pump you choose is the manual control, hasn't the signal connect, the panel operation function as following:

- A.  Adjust the the working frequency from 0-100%
- B.  Control the stop / start of the pump.
- C.  No function of this key.

6. Spare parts replacement and routine maintenance

6.1 Replace the Diaphragm

During the spare parts replacement and routine maintenance, please wear protective clothing, masks, safety mirrors, as well as gloves. Take additional precautions if necessary, according to the nature of the solution. please follow the protective measures suggested by the solution providers.

JCM metering pump designed for trouble-free operation, but for the pump in the best working condition, some of elastic parts (such as the diaphragm, seal ring, valve ball and injection valve spring) is essential to replace. We suggest you to change them once at least on an annual basis according to the condition of these parts. As the replacement of diaphragm, the other parts are to be replaced

The steps of changing diaphragm are shown as below:

- A. After pressure relief for discharge pipe, empty and remove discharge pipe. Put feet valve into the container with water or another neutral solution. Start pump, rinse pump head. Lift feet valve off the liquid surface and continue to run the pump, until the pump head filled with air inside. If the diaphragm is broken, and unable to work, carefully remove the suction and discharge pipe wearing the protective gloves. Remove the four screws on the pump head. Put the pump head into the water or another neutral solution.
- B. Start the pump. Transfer the stroke knob to zero during operation and then stop the pump.
- C. Pump closure. Carefully grasp the edge of diaphragm and twist it loose in the anti-clockwise direction. Discard the old diaphragm. Remove the disk on the back of the diaphragm (if any). And check if the size is fit with the new diaphragm.
- D. Move away the disk of the diaphragm and check the seal, if it is necessary, please replace the seal.
- E. Re-loaded the disk. Make sure its baseline align with the cavity.
Please take care and protect the surface of the diaphragm.
- F. Rotate the diaphragm clock wise until touch the bottom, open the pump and adjust the stroke to 100% position, then off the pump.
- G. After fix the diaphragm, put the pump head into the septa with four screws and tighten it.

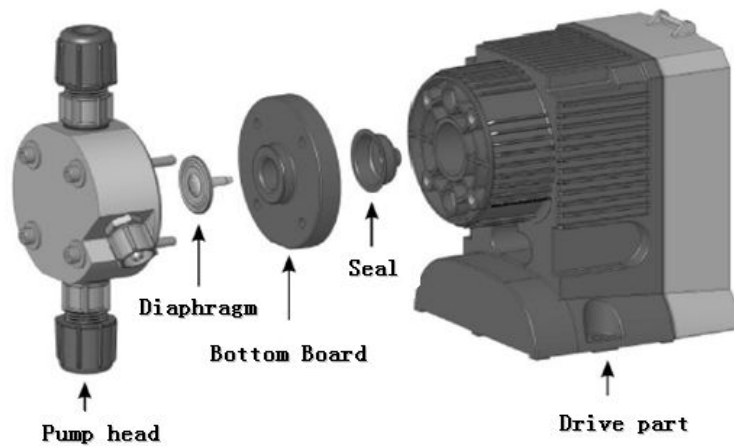

6.2 Replacement the O-ring Seal

During the spare parts replacement and routine maintenance, please wear protective clothing, masks, safety mirrors, as well as gloves.

- A. After Pressure relief for discharge pipe, empty and remove discharge pipe.
- B. Put feet valve into the container with water or another neutral solution. Start pump, rinse pump head. Lift feet valve off the liquid surface and continue to run the pump, until the pump head filled with air inside. If the diaphragm is broken, and unable to work, carefully remove the suction and discharge pipe wearing the protective gloves. Remove the four screws on the pump head. Put the pump head into the water or another neutral solution.
- C. Take off the pipe joints, and remove the damaged seal ring and valves ball. To get seal ring, a screwdriver can be used. hold it into the center of the ring, and try a few times along the left-right direction.
- D. Assemble the check valve, and please make sure the assembling is right.

6.3 The Replacement of the Injection Valve

During the spare parts replacement and routine maintenance, please wear protective clothing, masks, safety mirrors, as well as gloves.

- A. Separate the check valve, release the pipe pressure or drain the liquid in the tank.
- B. Disassemble the outlet pipe.
- C. Disassemble the pipe which is connected with the check valve, then disassemble the valve joint, replace the spring, valve seat, valve ball and O-ring seal.

Note: Before the disassemble, please make attention the mounting position of the spare parts.

- D. Assemble the new spring, valve seat, valve ball and O-ring seal.

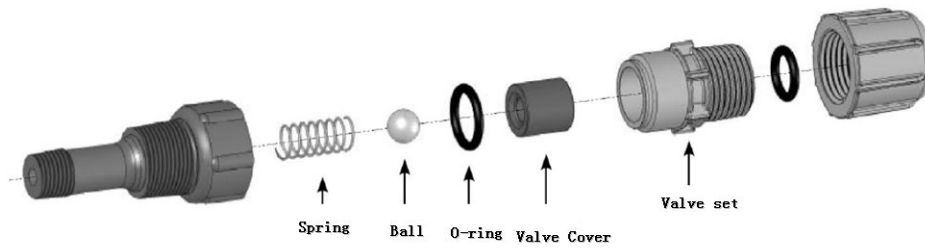

6.4 The Replacement of the O-ring on the Drawing Water Valve

During the spare parts replacement and routine maintenance, please wear protective clothing, masks, safety mirrors, as well as gloves.

A. Make sure the check valve has been assembled correct and under the correct operation, if there is a stop valve mounted at the backward of the check valve, the stop valve must be stopped. Also please make sure one of the branch pipe has been connected on the draw water valve, and the other branch pipe has been come back to the tank.

B. Rotate the draw water valve 1 circle and a half counter-clock wise, which let the pressure released and keep the valve open circuit. Pulled the return pipe gently then move the pipe from connection joint and hozzle.

C. Let the pipe be perpendicular to the tank until the solution has been reflowed to the tank.

D. Disassemble the screw, pull the whole draw water valve assembly, replace the two small O-ring seal.

E. Re-enter the whole draw water valve assembly and screw, then rotate the valve to the stop position.

F. Make sure the pipe end is smooth which is connected to the valve, then set the pipe in the joint.

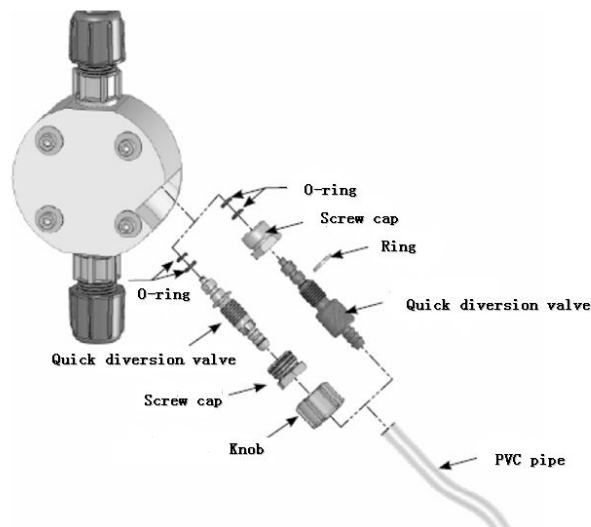

6.5 The Stroke Length Setting

All the knob of the stroke length for every pump has been checked, doesn't need to replace the

diaphragm and the other maintenance. But at once the adjustment knob has been disassemble, the stroke length need to be set again.

A. Assemble the new stroke shaft: Remember there will be the resistance if the O-ring from the stroke shaft rolls into the control panel.

The stroke shaft can be rotated by the adjustment knob, rotate the shaft continuously until there isn't any move for the diaphragm. In order to let the knob forward exactly, the pump need to be started. But before the start of the pump, please make sure the shaft has been touched with the plunger, or the pump will be damaged.

B. At once the shaft has been forwarded exactly, the stroke length can be re-set again. And it can be pressed when the adjustment needle is at 0% position.

C. Screw the stroke knob.

D. Inset the stroke needle to the adjustment knob.

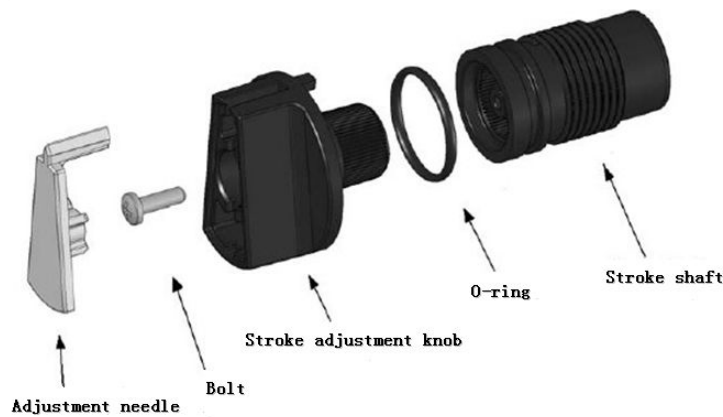

7. Trouble Shooting

FAULTS	REASONS	MEASRUES
The pump head can not infuse automatically.	1.the pump does not start or no power.	1.Start the pump or access the power.
	2.the pump output value is not set up	2.The rate must be transferred to 80%, stroke transferred to 100% when infusing the pump.
	3.Foot valve is not vertical to the bottom of the solution container.	3.Make Foot valve vertical to the bottom of the solution container.
	4.overflow pump's	4.pump's maximum suction range is 1.5

	maximum suction range.	meters. To handle high-viscosity material should use the priming installation.
	5.Suction pipe is distorted or coiled.	5.Suction pipe must be straightened using the ceramic tube.
	6.Connector screws too tight.	6.Connector twisting too tightly will make seal ring deformed and result in leakage.
	7.Suction tube with air.	7.Suction pipe must be kept vertical. So as to avoid false priming.
Pump head required to reperfusion	1.No solution in container.	1.add solution to the container and reperfusion
	2.Foot valve is not vertical to the bottom of the solution container.	2.Make Foot valve vertical to the bottom of the solution container.
	3.overflow pump's maximum suction range.	3.pump's maximum suction range is 1.5 meters. To handle high-viscosity material should use the priming installation.
	4.Suction tube is distorted or coiled.	4.Suction tube must be straightened using the ceramic tube.
	5.Connector screws too tight.	5.Connector twisting too tightly will make seal ring deformed and result in leakage.
	6.Suction pipe with air.	6.Suction pipe must be kept vertical. So as to avoid false priming.
	7.Air leakage at suction end.	7.Check whether the suction end has holes and cracks. Replace it if necessary.
Leakage of pipe	1.The end of pipe cracks.	1.Have the pipe cut off 1 inch (25 mm), and then reinstall.
	2.Connector loosens or cracks.	2.Replace the connector if it cracks. Carefully intall the joint, and do not use the wrench. Once the connector contacts seal ring. Re-precass 1/8 or 1/4 laps on it.
	3.Seal ring is broken.	3.Replace seal ring and valve ball.
	4.Head of pump is corroded by the solution.	4.Contact the AILIPU company or the local dealer for the suitable material.
Output flow is too small, or pump does not work under the pressure.	1.The maximum rated discharge pressure of pump is less than the injection pressure.	1.Injection pressure can not exceed the maximum pressure of pump.
	2.Seal ring is broken.	2.Replace seal ring and valve ball.
	3.Diaphragm is ruptured.	3.Replace diaphragm.
	4.Stroke length is set incorrectly	4.Check the pump's zero position, reset it.
	5.Discharge tube is too long.	5.Pipe is too long will due to friction loss of pump's rated pressure

	6.Foot valve filter clogs.	6.When pumping viscous materials or solutions that make the filter blocked,remove the filter.
--	----------------------------	---

Appendix

1. The spare parts list of the drive part

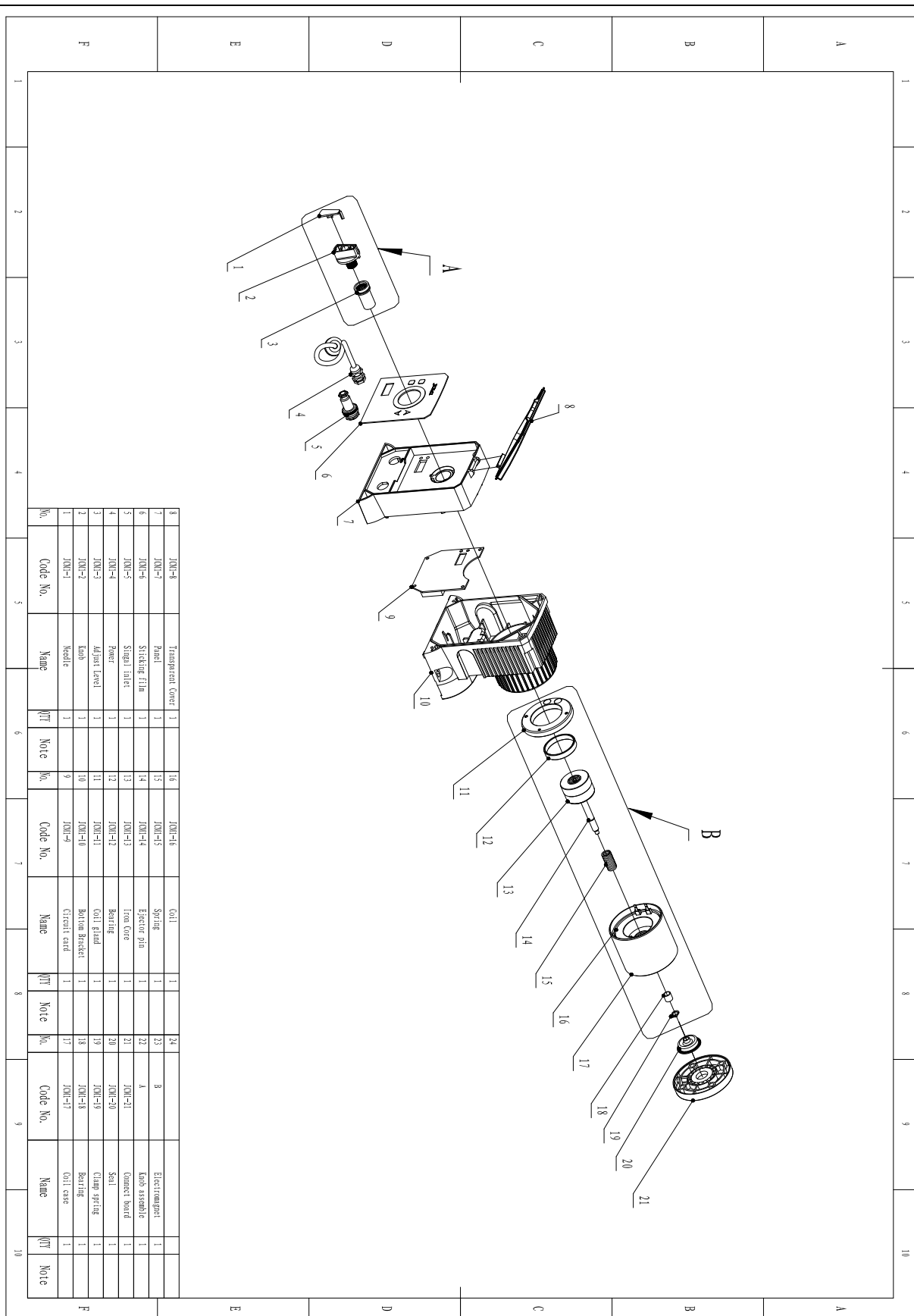

(注：把这张图替换掉，换成图 1)

2. There are 3 kinds of pump heads specification for our customer's choice:
 - A. Normal standard pump head.

B. Pump head with the air-release valve.

C. Pump head with the 4-FV.

Note: For our normal order, all the pump heads are the normal standard type, without the air-release valve and 4-FV. If the customer need B or C type pump head, please remark that and the price need to be added.

2.1 The Pump Head Spare Parts List (With the Air-release Valve)

(注：此处插入图 2)

2.2 The Normal Standard Pump Head Spare Parts Drawing.

(注：此处插入图 3)

2.3 The Spare Parts Drawing for the Pump Head with Air-Release Valve.

(注：此处插入图 4)

Remark: There are 2 function for this pump head: a: Air release when open the pump.
b: Sampling.

2.4 The Spare Parts Drawing for the Pump Head with 4-FV.

(注：此处插入图 5)

Remark: There are 2 function for this pump head: a: Air release when open the pump.
b: Sampling.
c: Safety valve function
d: Check valve function

2.5 Pipe Fitting:

There are 2 kinds of injection valves from us for our customer's choice, one is spring type injection valve, another one is the diaphragm type injection valve. Please check the following drawing details.

A. Spring Type Injection Valve

(注：此处插入图 6)

B. Diaphragm Type Injection Valve

(注：此处插入图 7)

3. The outline drawing of JCM1

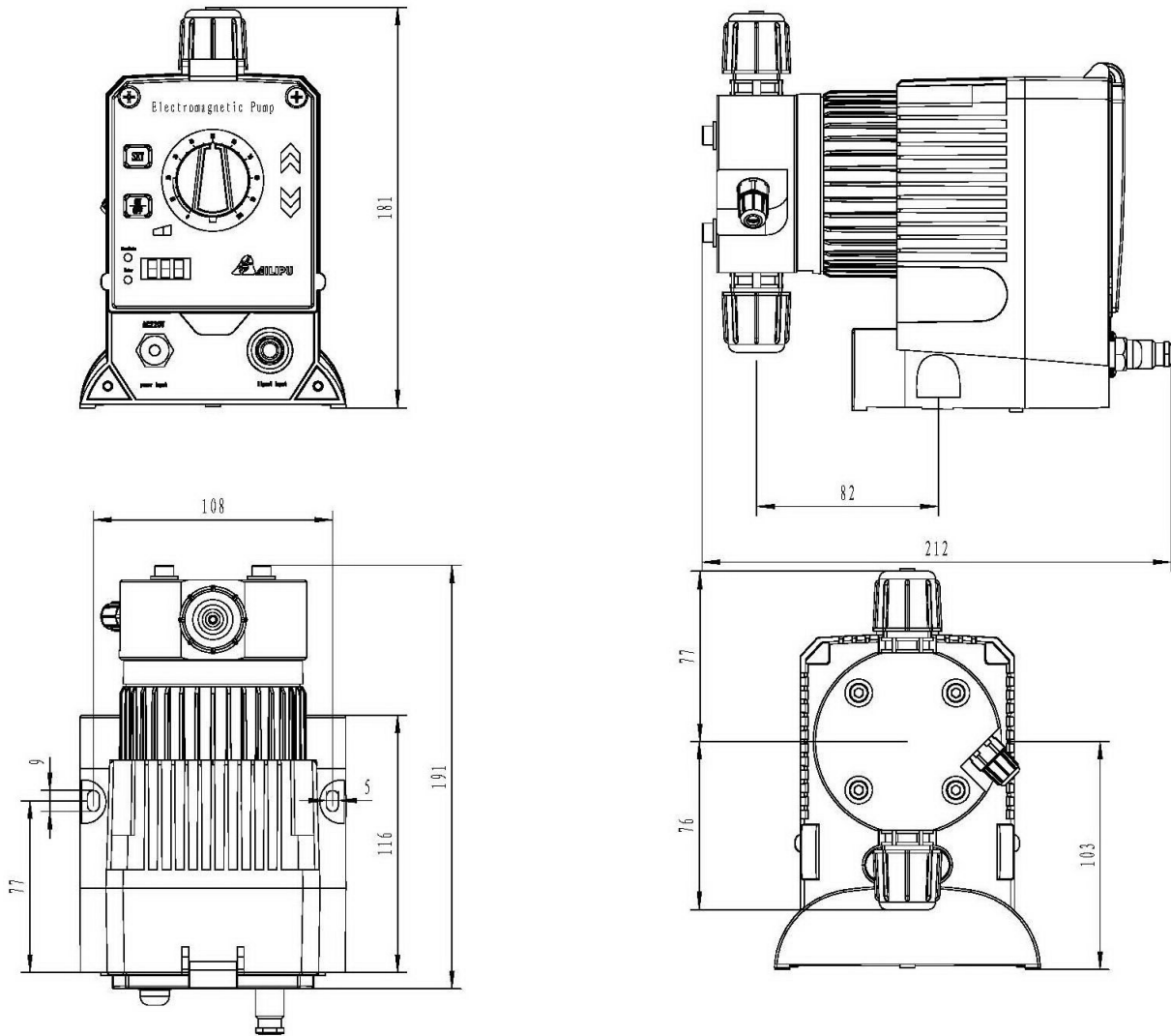

4. Type Choice

Type	Max Capacity Flow	Max Pressure	Pipe Size	Pipe Material
JCM1-1/20.7	1.0L/H	20.7bar	6mm*9.5mm	PE
JCM1-1.9/17.2	1.9 L/H	17.2bar	6mm*9.5mm	PE
JCM1-3.8/7.6	3.8L/H	7.6bar	6mm*9.5mm	PE
JCM1-7.6/3.4	7.6L/H	3.4bar	6mm*9.5mm	PE
JCM1-12.1/1.5	12.1L/H	1.5bar	6mm*9.5mm	PE
JCM1-15.1/1.0	15.1L/H	1.0bar	6mm*9.5mm	PE
JCM1-20/1.0	20L/H	1.0bar	6mm*9.5mm	PE

Attachment

8 Line Cable Singal Connection.

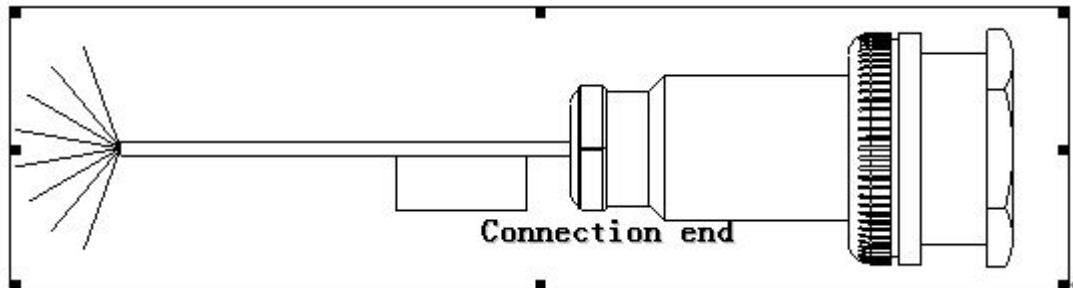

A. With 4-20mA Signal Connection End:

No.	Cable Color	Singal
1	Brown	Remote stop & start
2	Red	Remote stop & start
3	Blue	4-20mA Output -
4	Grey	4-20mA Input +
5	White	Liquid Level Alarm
6	Green	Liquid Level Alarm
7	Black	Reserve
8	Yellow	Reserve

B. With Pulse Signal Connection End

No.	Cable Color	Singal
1	Brown	Remote stop & start
2	Red	Remote stop & start
3	Blue	Pulse Signal Output -
4	Grey	Pulse Signal Input +
5	White	Liquid Level Alarm
6	Green	Liquid Level Alarm
7	Black	Pulse Feedback -
8	Yellow	Pulse Feedback +

Remark: All the No.have been marked on the signal plug.